

Dynapac SD2500CS

Tracked pavers

Atlas Copco



Technical data



Masses

Weight (incl. standard screed)	18.50 t
--------------------------------	---------



Dimensions

Basic width	2.55 m
Working width, max.	10.00 m
Working width, minimum (with reducing shoe)	2.05 m
Front ramp angle	15°



Capacity

Placement thickness (max)	310 mm
Theoretical placement capacity	800 t/h



Material hopper

Capacity	6.0 m ³
Dumping height (center/outside)	555 mm /560 mm
Hopper width, internal	3,292 mm



Traction

Maximum paving speed	28 m/min
Transport speed	4 km/h



Engine

Manufacturer/Model	Cummins QSB 6.7-C200
Emissions according to	Stage IIIB/IV (T4i/4)
Rated power, SAE J1995	149 kW (202 hp) @ 2.200 rpm with stepless rpm control and eco-mode
Electrical system	24 V
Fuel tank capacity	350 l



Engine

Manufacturer/Model	Cummins QSB 6.7-C190
Emissions according to	Stage IIIA (T3)
Rated power, SAE J1995	142 kW (193 hp) @ 2,200 rpm with stepless rpm control and eco-mode



Undercarriage

Crawler length	2,900 mm
Crawler width	320 mm
Final drive	Hydrostatic final drives with hydraulic motors and planetary gear box



Conveyor

Conveyor type	Dual bar feeder
Conveyor width	2 x 655 mm
Conveyor control	Automatic with limit switches



Auger

Auger diameter	380 mm
Auger control	Automatic with ultrasonic sensors

Find us locally at www.atlascopco.com

We reserve the right to change specifications without notice. Photos and illustrations do not always show standard versions of machines. The above information is a general description only, all informations are supplied without liability.

rce_sd2500cs_en-20141212.130541.pdf 2014-12-12 13:05

Dynapac SD2500CS

Tracked pavers

Atlas Copco

Technical data

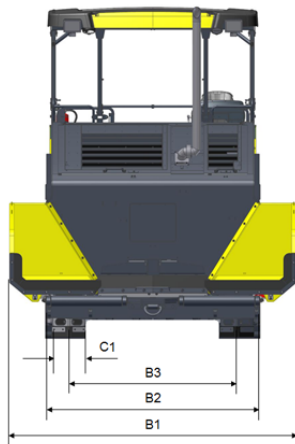
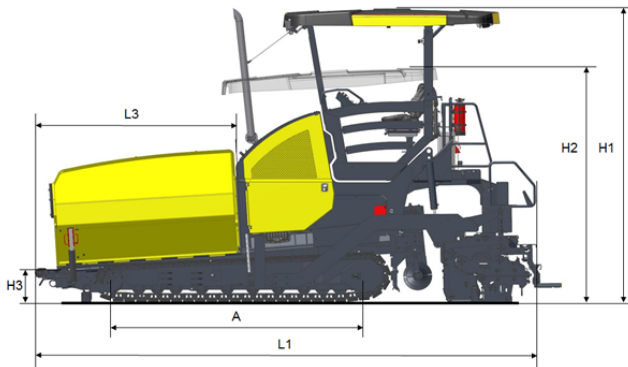

Dimensions	
A. Axle track	2,900 mm
B1. Width, max.	3,400 mm
B2. Width, standard	2,550 mm
B3. Width, center of tracks	1,992 mm
C1. Track width	320 mm
H1. Height, max.	3,900 mm
H2. Height, transport	3,100 mm
H3. Height	492 mm
L1. Length	6,145 mm
L3. Length, hopper	2,123 mm



Standard equipment

Equipment	Standard	Plus (T4i)
Reversible conveyor, separate control	■	
Reversible HC Conveyor, separate control		■
Hydraulic crowning adjustment		■
Comfort seats	■	
Grammer seats (heated)		■
2 front & 2 rear halogen lights	■	
2 front & 2 rear LED lights		■

Find us locally at www.atlascopco.com

We reserve the right to change specifications without notice. Photos and illustrations do not always show standard versions of machines. The above information is a general description only, all informations are supplied without liability.

rce_sd2500cs_en-20141212.130541.pdf 2014-12-12 13:05